



# Hydraulic Earth Auger Attachments

Models:  
MD06PD, MD09PD, MD12PD, MD14PD, MD18PD

## OPERATOR'S MANUAL

Serial Number \_\_\_\_\_

Model Number \_\_\_\_\_



**WARNING!** Avoid injury or death. Read and understand this entire manual before installing, operating or servicing this equipment.



# TABLE OF CONTENTS

To The Owner .....	2
Warranty Registration Form .....	3 – 4
Warranty Policy .....	5
Safety Information .....	6 – 7
Skid Steer Loader Installation Instructions .....	8
Backhoe & Excavator Installation Instructions .....	9
Hydraulic Hookup Instructions .....	10
Operating Instructions .....	11
Maintenance Instructions .....	12
Troubleshooting .....	13
Drive Unit Models MD06PD, MD09PD, MD12PD - Exploded View and Specifications .....	14
Drive Unit Models MD14PD, MD18PD - Exploded View and Specifications .....	15
Power Wheel Service Procedures .....	16 - 17
Drive Unit Motor Exploded View.....	18
Drive Unit Motor Parts List .....	19
Drive Unit Motor Service Procedures .....	20 – 23
Accessories & Auger Replacement Wear Parts .....	24

## ***Congratulations on the purchase of your PREMIER Hydraulic Earth Auger Attachment.***

You have invested in a quality piece of equipment backed by people with years of experience. But only by proper installation, operation, and maintenance can you expect to receive the dependable performance and long life for which the earth auger was designed.

This operator's manual contains information regarding the installation, operation, safe use, and maintenance of your Premier Hydraulic Earth Auger Attachment. ***Please be sure all operators study this manual carefully and keep it on file for future reference.***

After reading this manual, if you have any questions about your Premier Hydraulic Earth Auger Attachment please contact us immediately as follows:

**Toll Free:** (866) 458-0008  
**Local:** (260) 456-8518  
**Fax:** (260) 456-6868  
**Web:** [www.premierauger.com](http://www.premierauger.com)  
**E-Mail:** [contact@premierauger.com](mailto:contact@premierauger.com)

Premier Auger strives to provide superior products and the highest level of customer service. If you have any suggestions on how we can improve for the future, we would appreciate hearing from you.

*Thank you for putting your trust in PREMIER.*

## **PREMIER Hydraulic Augers, Inc.**

2707 Lofty Drive  
Fort Wayne, IN 46808

# PREMIER HYDRAULIC AUGERS WARRANTY REGISTRATION

Date of Purchase: \_\_\_\_\_

Model #: \_\_\_\_\_ Serial #: \_\_\_\_\_

## Owner Information:

Owner's Name \_\_\_\_\_ Phone \_\_\_\_\_

Company Name \_\_\_\_\_

Address \_\_\_\_\_

City \_\_\_\_\_ State \_\_\_\_\_

Zip Code \_\_\_\_\_ Country \_\_\_\_\_

## Dealer Information:

Dealer Salesman \_\_\_\_\_ Phone \_\_\_\_\_

Dealer Name \_\_\_\_\_

Address \_\_\_\_\_

City \_\_\_\_\_ State \_\_\_\_\_

Zip Code \_\_\_\_\_ Country \_\_\_\_\_

## Installation & Application Information:

This Premier Hydraulic Earth Auger will be mounted on: \_\_\_\_\_

This Premier Hydraulic Earth Auger Attachment has been accepted in good condition and I have been instructed by the dealer and/or read and understand the entire Operator's Manual for proper installation, proper and safe operation, preventative maintenance and service, warranty and all other information covered in the Operator's Manual. I also understand that all operators must read and understand the entire Operator's Manual.

Owners Signature \_\_\_\_\_

***This page must be returned within 10 days of purchase to validate warranty.***

**Return To:** Premier Hydraulic Augers, Inc.  
2707 Lofty Drive  
Fort Wayne, IN 46808

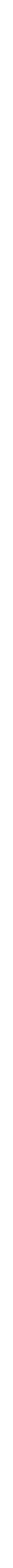

# PREMIER HYDRAULIC AUGER WARRANTY POLICY

Model # \_\_\_\_\_ Serial # \_\_\_\_\_

Premier warrants its products to be free from defects in material or workmanship for a warranty period as stated below.

**EARTH AUGER MD DRIVE UNITS: 24 MONTHS**  
**AUGER BITS & MOUNTINGS: 12 MONTHS**

The warranty period begins on the date of purchase by the original purchaser.

## Warranty Performance

To make a claim under this warranty, contact the dealer purchased from, who will then obtain written return authorization from Premier. All warranty returns must be accompanied by a Premier Auger's Return Authorization.

## Remedy

During the applicable warranty period Premier Auger at its option will repair or replace, free of charge, any product determined by it to be defective. Such repair or replacement shall take place at a location designated by Premier Augers.

## Exclusions From Warranty Coverage

1. This warranty automatically is void if any attempt is made to make field repairs to hydraulic motors or planetary gear reductions. To qualify for warranty performance the complete unit must be available for Premier Auger's inspection in its original "failed" condition.
2. There is no warranty against failures caused by or related to alterations or modifications made without the express written consent of Premier Auger.
3. Under no circumstances shall Premier Auger be responsible for the cost of labor for field replacement or repair, nor for damage caused by accident, misapplication, abuse, misuse, operator error, or environmental elements.
4. This warranty does not apply to parts subject to normal wear, such as auger teeth and points, nor to damage caused by the failure to perform recommended maintenance or to replace worn parts.
5. Under no circumstances shall Premier Auger be obligated for the cost of any repair or replacement by anyone other than Premier Auger, without its express written consent.

## Limitations And Exclusions

This warranty is in lieu of all other warranties written or oral, express or implied, statutory or otherwise arising by operation of law, including any warranty of merchantability or fitness for purpose.

The liability of Premier Auger arising out of the supplying of any product covered by this warranty contract, negligence or otherwise shall not in any case exceed the cost of parts or labor required to rebuild or replace such defective product, together with the transportation costs attributable thereto. Upon the expiration of the applicable warranty period herein specified, all such liability shall terminate.

This warranty constitutes the entire warranty of Premier Auger, and no oral representations, warranties or guarantees by any agent of Premier Auger, or the seller shall be binding on Premier Auger, and no part of this warranty may be modified or extended except upon the express written consent of Premier Auger.

## Improvements

Premier Auger continually strives to improve our products. Premier Auger reserves the right to make changes or additions to any product without incurring any obligation whatsoever to make such changes or additions to products previously sold.

# SAFETY INFORMATION

THE USE OF THIS EQUIPMENT IS SUBJECT TO CERTAIN HAZARDS WHICH CANNOT BE PROTECTED AGAINST MECHANICAL MEANS OR PRODUCT DESIGN. ALL OPERATORS OF THIS EQUIPMENT MUST READ AND UNDERSTAND THIS ENTIRE MANUAL, PAYING PARTICULAR ATTENTION TO SAFETY AND OPERATING INSTRUCTIONS, PRIOR TO USING THE PREMIER AUGER HYDRAULIC EARTH AUGER. IF THERE IS SOMETHING IN THIS MANUAL YOU DO NOT UNDERSTAND, ASK YOUR SUPERVISOR TO EXPLAIN IT TO YOU. FAILURE TO OBSERVE THESE SAFETY PRECAUTIONS CAN RESULT IN DEATH OR SERIOUS INJURY OR SERIOUS EQUIPMENT DAMAGE.



All bystanders should be kept a minimum of 10 feet away from working area of the earth auger.



Always wear an OSHA approved hard hat and safety eye protection when operating or servicing this equipment. Do not wear loose fitting clothing, flopping cuffs, dangling neckties and scarves, or rings and wrist watches that can catch moving parts.



An operator must not use drugs or alcohol, which can alter his alertness or coordination. An operator taking prescription or over the counter drugs should seek medical advice on whether or not he can safely operate equipment.



Always locate underground electrical wires, telephone cables, and gas, water, and sewer lines before digging. Maintain safe clearance and avoid contact with any underground or overhead utility lines or electrically charged conductors.



Never alter or remove any safety decals or safety shields. Check this manual for location of these items and replace immediately if damaged or illegible.



Never adjust a relief valve for pressure higher than recommended by vehicle manufacturer.



Whenever changing or installing this or other attachments, make sure all connections are securely fastened.



Travel only with the earth auger in a safe transport position to prevent uncontrolled movement. Drive slowly over rough ground and on slopes. Tether earth auger with a chain, if necessary, to prevent uncontrolled swinging of earth auger when moving from hole to hole. Remove earth auger from vehicle when transporting to and from job site.



Before exiting the vehicle, lower earth auger to ground, turn off vehicle engine and lock vehicle breaks.

*(continued)*



# SAFETY INFORMATION



Never check a pressurized system for leaks with your bare hand. Oil escaping from pin-hole leaks under pressure can penetrate skin and could cause serious infection. Hold a piece of cardboard up next to suspected leaks and wear a face shield or safety eye protection. If any fluid is injected into the skin, it must be removed immediately by a doctor familiar with this type of injury.



Before disconnecting hydraulic lines or fittings be sure to relieve all pressure by cycling all hydraulic controls after shutdown. Remember hydraulic systems are under pressure whenever the engine is running and may hold pressure after shutdown. Before applying pressure to the system make sure all connections are tight and that there is no damage to lines, fittings, and hoses.



Flow and pressure gauges, fitting, and hoses must have a continuous operating pressure rating of at least 25% higher than highest pressures of the system.



Avoid steep hillside operation, which could cause the vehicle to overturn. Consult your vehicle operator's and safety manuals for the maximum incline allowable.



Never perform any work on an earth auger unless you are authorized and qualified to do so. Always read the operator service manual before any repair is made. After completing maintenance or repair, check for correct functioning of the earth auger. If not functioning properly always tag "DO NOT OPERATE" until all problems are corrected.



This manual covers the safe use, installation, operation, and service instructions for the earth auger only. Always read the operating and safety manuals prepared for your vehicle and any other attachments before using them.

# SKID STEER LOADER INSTALLATION INSTRUCTIONS

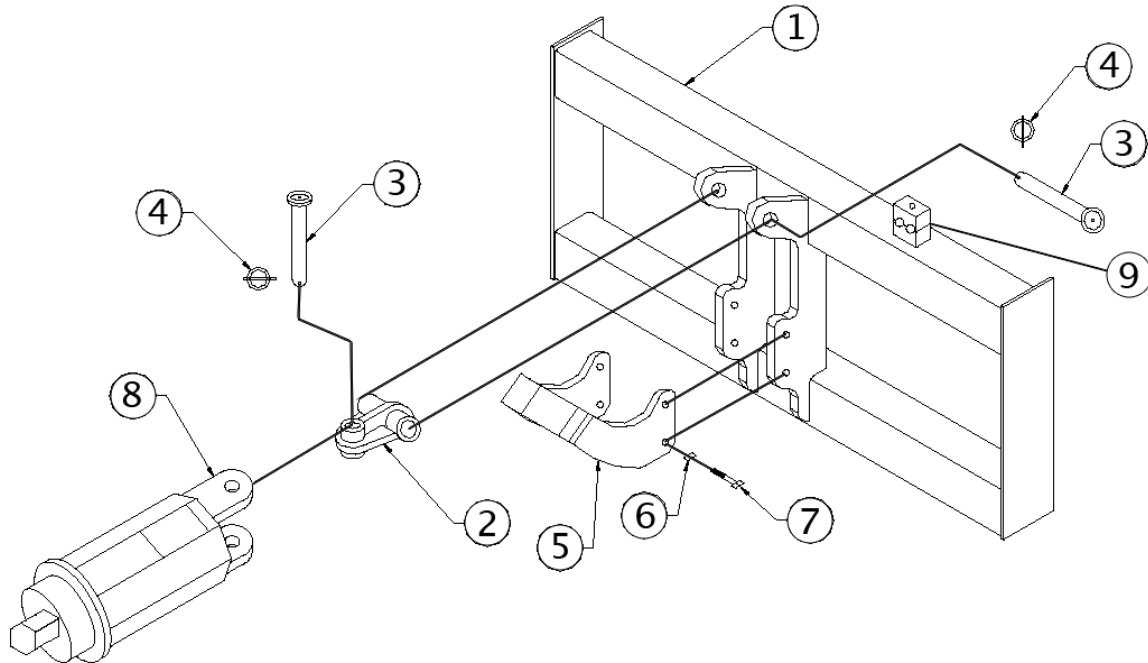

## QUICK ATTACH MOUNTING BRACKET

<u>Ref.#</u>	<u>Part #</u>	<u>Description</u>
1	95000	Mount Weldment
2	91002	Knuckle Weldment
3	91001	Pin Weldment
4	40009	Snap Pin
5	91003	Carrier Weldment
6	40005	1/2\"-13 Nut
7	40006	1/2\"-13 HHCS 2-1/4\" Long
8	N/A	Drive Unit
9	40018	Hose Holder

- 1. READ AND UNDERSTAND ALL SAFETY INFORMATION BEFORE ATTEMPTING INSTALLATION.**
- Remove bucket or other attachment from vehicle quick attach mechanism.
- Assemble carrier weldment (5) to quick attach mounting bracket (1) with supplied 1/2\"-13 HHCS 2\" Long (7) and 1/2\"-13 (6) hex nut.
- Attach quick attach mounting bracket (1) to vehicle quick attach mechanism as per vehicle manufacturer's recommendations.
- Attach knuckle weldment (2) to the quick attach mounting bracket (1) with pin (3). Secure pin (3) with supplied snap clip (4).
- Attach and secure drive unit (8) to knuckle weldment (2) with pin (3). Secure pin (3) with supplied snap clip (4).
- Refer to the "Hydraulic System Hook-up" (page 11) in this manual for hydraulic connection instructions and recommendations.

# BACKHOE & EXCAVATOR INSTALLATION INSTRUCTIONS

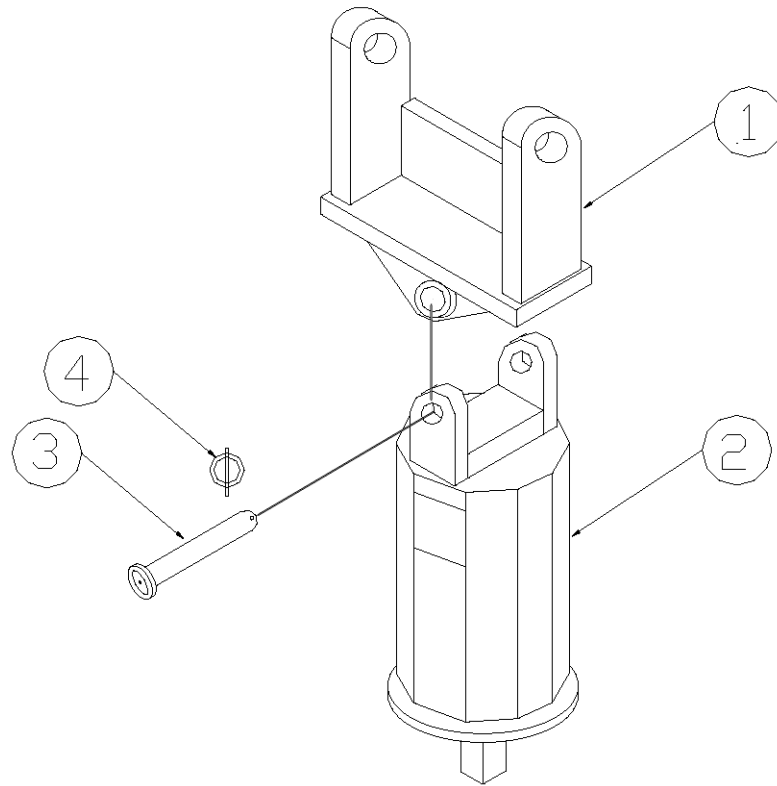

<b>Ref.#</b>	<b>Part #</b>	<b>Description</b>
1	.....(Varies by Host Machine)	.....Backhoe Mounting Bracket
2	.....(Varies by Host Machine)	.....Drive Unit
3	.....91001	.....Pin Weldment
4	.....40009	.....Snap Pin

1. **READ AND UNDERSTAND ALL SAFETY INFORMATION BEFORE ATTEMPTING INSTALLATION.**
2. Remove bucket from dipper arm and curl cylinder pin connections. The dipper arm pin will be used to attach backhoe mounting to backhoe dipper arm. Curl cylinder pin will not be required for earth drill installation.
3. Attach backhoe mounting bracket (1) to the dipper arm using the dipper pin removed from bucket in step #2. Secure bucket pin as per vehicle manufacturer's recommendation.
4. Attach drive unit (2) to backhoe mounting bracket (1) with pin weldment (3) and snap pin (4) supplied with drive unit.
5. Refer to the "Hydraulic System Hook-up" section in this manual for hydraulic connection instructions and recommendations.

## HYDRAULIC SYSTEM HOOK-UP INSTRUCTIONS

1. Once the installation instructions are complete you are now ready to make the hydraulic connections necessary to operate your earth drill. **Read and understand safety information prior to making hydraulic connections.**
2. Your equipment dealer is in the best position to advise you as to where the best place on your machine is to make the hydraulic connections to power your earth drill drive unit. Some of the most common places to “tap” into the hydraulic system on various types of machines are as follows:

**Skid Steer Loaders** .....Auxiliary Hydraulic Outlets.

**Backhoes & Excavators** .....Auxiliary Hydraulic Outlets or Bucket Curl Cylinder Outlet.

**Wheel Loaders** .....Auxiliary Hydraulic Outlets or Bucket Dump Cylinder Circuit.

3. Determine the length of hydraulic hoses required to plumb drive unit into the place on your machine where you will be “tapping” in to the hydraulics. Be sure the two hydraulic hoses are long enough to perform at the full range of the earth drills’ operating capacity.
4. Models MD06PD, MD09PD, MD12PD, MD14PD, and MD18PD require two ½” I.D. hoses with #10 JIC female fittings on one end of each to connect hoses to drive unit fittings.
5. Once all hydraulic connections have been made and checked for leaks and proper hose lengths, you are now ready to operate your earth drill. **Read and understand operating instructions and safety information prior to operating your earth drill.**



**WARNING! Hoses and Fittings must have a Continuous Operating Pressure Rating of at least 25% Higher than the Highest Pressures of the System that you are “tapping” into.**

## OPERATING INSTRUCTIONS

1. After all installation instructions have been completed, safety information read and understood and the rest of this operator's manual has been reviewed, your Hydraulic Earth Drill is now ready to use.
2. With the auger raised off the ground and the vehicle engine set at a low RPM, activate the earth drill control valve to determine position control valve lever must be in to turn auger in a forward (clockwise) rotation. This is the "digging" position.
3. Before beginning to dig, experiment with auger speed to determine a suitable auger RPM. Generally in light and sandy soil a high RPM is desirable. In hard, rocky, or frozen soils a slower RPM is desirable. To increase auger RPM, increase vehicle engine RPM. To decrease auger RPM, decrease vehicle engine RPM.
4. Return earth drill control valve to neutral position to stop the auger. Lower the auger to the ground so that only the center point penetrates the ground about 2".
5. Activate the earth control valve so auger is turning in a forward (clockwise) rotation. Use only enough down pressure to assure positive penetration of auger into the ground. Ease up on down pressure if auger rotation slows down drastically or stalls. Excessive down pressure will cause the auger to stall frequently.
6. When the auger has penetrated the ground about 24", raise the auger from the hole to clean the dirt out. Repeat this procedure until the desired hole depth is obtained.
7. Once the required hole depth is reached, allow the auger to turn a few seconds at this depth to clean the hole.
8. Return the earth drill control valve to the neutral position to stop the rotation of the auger. Raise the auger out of the hole, move away from the hole, then activate the earth drill control valve to spin the loose soil off of the augers.
9. If necessary, repeat steps 7 & 8 to obtain a cleaner hole.
10. In some soil conditions or when excessive down pressure is applied, auger may "screw" itself into the ground and become stuck causing earth drill to stall. If this happens, reverse the auger rotation (counter Clockwise) by moving the control valve lever to the reverse position and slowly raise the auger. Once the auger is unstuck, return the control valve lever to the forward position and continue digging.
11. If the auger becomes lodged under rocks, roots, or other large obstructions, do not attempt to raise auger out of the ground. See step 10 for proper procedure to relieve the auger.
12. Avoid excessive side loading to the earth drill which can cause drive unit or auger damage.
13. Keep auger teeth and points in good condition. Check frequently and always keep spares on hand so they can be replaced as wear is detected to avoid damage to tooth holders and auger flighting.

## MAINTENANCE INSTRUCTIONS

1. **CLEAN HYDRAULIC OIL IS ESSENTIAL!** 80% of all hydraulic component failures are caused by contamination of the hydraulic oil. Always keep all dirt and other contaminants from entering hydraulic system during disconnect and connect operations. Always use dust caps and plugs on all quick disconnects when not in use. Tightly cap all hydraulic openings to hold oil in and keep dirt and other contaminants from entering hydraulic systems.
2. **CHECK ALL HYDRAULIC OIL DAILY FOR CONTAMINATION.** If contamination is present, determine the source of the problem.
3. **INSPECT ALL HYDRAULIC HOSE ASSEMBLIES DAILY** for cracked and brittle covers caused by excessive heat. Reduced viscosity of hydraulic oil occurs at higher operating temperatures and causes a breakdown of fluid additives such as wear inhibitors. Excessive heat will cause higher internal leakage in drive unit motor to become brittle and crack. Replacement of hoses before failure will prevent loss of hydraulic oil, time consuming “bleeding” of system, hydraulic oil contamination, and component damage caused by cavitations. It will also reduce the chance of personal injury caused by hydraulic fluid.
4. **CHECK AUGER DAILY** for loose, worn or broken cutting teeth and point. Worn teeth or point can drastically affect auger penetration and greatly reduce auger life expectancy. Always keep spare teeth and points on hand. Some digging conditions may require checking teeth and point at more frequent intervals.
5. **CHECK DRIVE UNIT AND ALL ACCESSORIES DAILY** for loose, bent, cracked, or worn, bolts and fasteners. Always use grade 5 or better replacement bolts. Always use lock washers with standard hex nuts or self locking nuts.
6. **CHECK ALL CONNECTING PINS DAILY** for bends, cracks, breaks, or wear. Replace if any of these conditions exist.
7. **CHECK DRIVE UNIT OUTPUT SHAFT DAILY** for bends, cracks, breaks, or wear. Replace if any of these conditions exist.
8. **CHANGE PLANETARY GEAR REDUCTION OIL AFTER FIRST 50 HOURS OF OPERATION, THEN EVERY 1000 HOURS OR IN ONE YEAR, WHICHEVER COMES FIRST.** Use mild extreme pressure lubricant API-GL-5 number 80 or 90 for filling planetary gear reduction under normal temperature ranges between 0 degrees and 120 degrees. Approximate oil capacity for models MD06PD, MD09PD and MD12PD is 1 pint. Approximate oil capacity for models MD14PD and MD18PD is 1.5 pints. Check oil level daily to assure proper lubrication is maintained.
9. When storing Drive Unit for any length of time be sure Drive Unit motor and hoses are full of clean oil. Also, be sure that Planetary Gear Reduction is full to the recommended capacity for each model as outlined in number 8 above.
10. Drive Unit output shaft, inside of Auger Collar, Variable Auger Extension shaft, inside of Variable Auger Extension Collar and all Connecting Pins should be coated liberally with grease as required to prevent rust and reduce wear.
11. Once paint has been worn off auger, coat liberally with grease as required, to prevent rusting.
12. Check Planetary Gear oil as follows. Lie Drive Unit horizontal with ground place bottom drain plug straight up. Remove plug, tilt drive unit at 2:00 or 10:00. Fill until oil leaks out from hole at one of these positions.

## TROUBLESHOOTING

Problem	Possible Cause	Solution
Slow Speed	Low flow	Check Flow Meter. If low, investigate the cause.
	Line restrictions	Clear lines.
	Fittings or connections too small	Replace with proper sizes.
	Oil filter dirty	Replace.
	Hydraulic pump worn or damaged	See Dealer for repair.
Insufficient Digging Power	Worn Teeth Or Point	Replace.
	Low System Pressure	Check Pressure Gauge. If low, investigate cause.
	Relief Valve damaged or setting wrong	Adjust or replace as required.
	Excessive Load	Reduce load to within machine specifications.
Reverse Direction	Hoses Reversed	Re-install hoses correctly.
Excessive Oil Heating	Line Restrictions	Clear lines.
	Fluid Dirty	Replace hydraulic fluid & filter.
	Insufficient amount of hydraulic fluid	Fill reservoir to proper level. Increase reservoir storage capacity.
Oil Leaks	Hoses loose or damaged	Tighten or replace.
	Fittings loose or damaged	Tighten or replace.
	Hydraulic motor seals worn or damaged	See dealer for repair.

***For further assistance, please call your dealer, or contact our sales department as follows:***

**Toll Free:** 866-458-0008  
**Local:** 260-456-8518  
**Fax:** 260-456-6868

# DRIVE UNIT MODELS MD06PDH200, MD09PDH200, MD12PDH200 EXPLODED VIEW AND SPECIFICATIONS

## MODEL MD06PD

Maximum Auger Diameter: .....15"  
 Recommended Hydraulic Flow .....5 - 10 gpm  
 Maximum Continuous Operating PSI: .....3500 psi  
 Maximum Back Pressure: .....1500 psi

Output Speed		Output Torque	
GPM	RPM	PSI	LB/F
05	52	2500	734
07	73	3000	881
09	93	3500	1028
10	104		

## MODEL MD09PD

Maximum Auger Diameter: .....18"  
 Recommended Hydraulic Flow .....5 - 10 gpm  
 Maximum Continuous Operating PSI: .....3500 psi  
 Maximum Back Pressure: .....1500 psi

Output Speed		Output Torque	
GPM	RPM	PSI	LB/F
07	48	2500	1123
09	61	3000	1347
11	75	3500	1571
13	88		

## MODEL MD12PD

Maximum Auger Diameter: .....24"  
 Recommended Hydraulic Flow .....5 - 10 gpm  
 Maximum Continuous Operating PSI: .....3500 psi  
 Maximum Back Pressure: .....1500 psi

Output Speed		Output Torque	
GPM	RPM	PSI	LB/F
09	49	2500	1409
11	59	3000	1691
13	71	3500	1972
15	81		

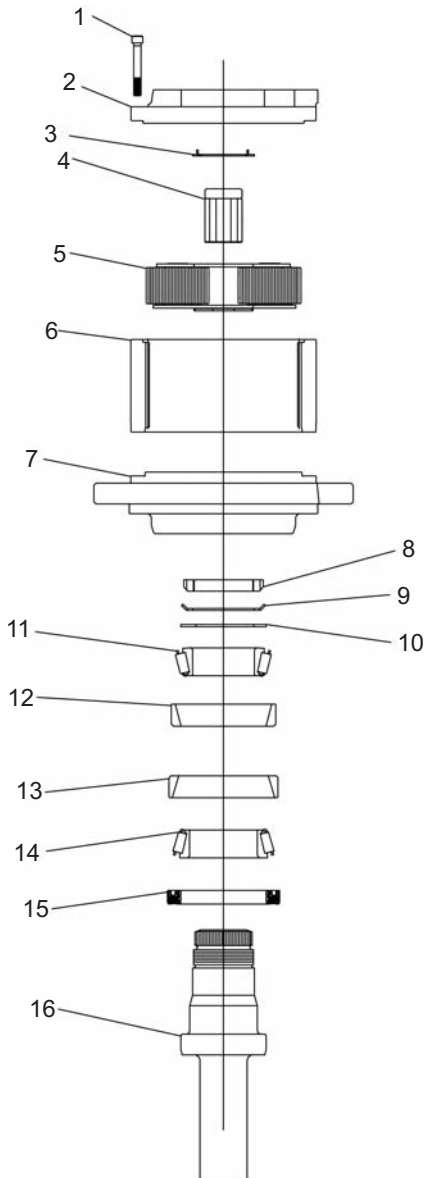

<u>Ref.#</u>	<u>Part #</u>	<u>Description</u>
1	69303	Socket Head Cap Screws (12 required)
2	69304	Cover Plate
3	69305	Thrust Washer
4	69306	Sun Gear
5	69307	Carrier Assembly
6	69308	Ring Gear
7	69309	Hub
8	69310	Bearing Nut
9	69311	Lock Washer
10	69312	Output Shaft Thrust Washer
11	69313	Inner Bearing Cone
12	69314	Bearing Cup
13	69315	Bearing Cup
14	69316	Outer Bearing Cup
15	69317	Output Shaft Seal
16	69318	Output Shaft

**\*NOTE:** 1 Pint of Oil Required



# DRIVE UNIT MODELS MD14PD, MD18PD

## SPECIFICATIONS, EXPLODED VIEW, PARTS LIST

### MODEL MD14PD

Maximum Auger Diameter: .....30"  
 Minimum Hydraulic Flow: .....10 gpm  
 Maximum Hydraulic Flow: .....20 gpm  
 Maximum Continuous Operating PSI: .....3500 psi  
 2-9/16" Round or 2" Hex Output Shaft

<u>Output Speed</u>		<u>Output Torque</u>	
GPM	RPM	PSI	LB/F
12	50	2500	1825
15	61	3000	2190
17	71	3500	2555
20	83		

### MODEL MD18PD

Maximum Auger Diameter: .....36"  
 Minimum Hydraulic Flow: .....15 gpm  
 Maximum Hydraulic Flow: .....30 gpm  
 Maximum Continuous Operating PSI: .....3500 psi  
 2-9/16" Round or 2" Hex Output Shaft

<u>Output Speed</u>		<u>Output Torque</u>	
GPM	RPM	PSI	LB/F
15	50	2500	2290
18	60	3000	2748
20	67	3500	3206
25	83		

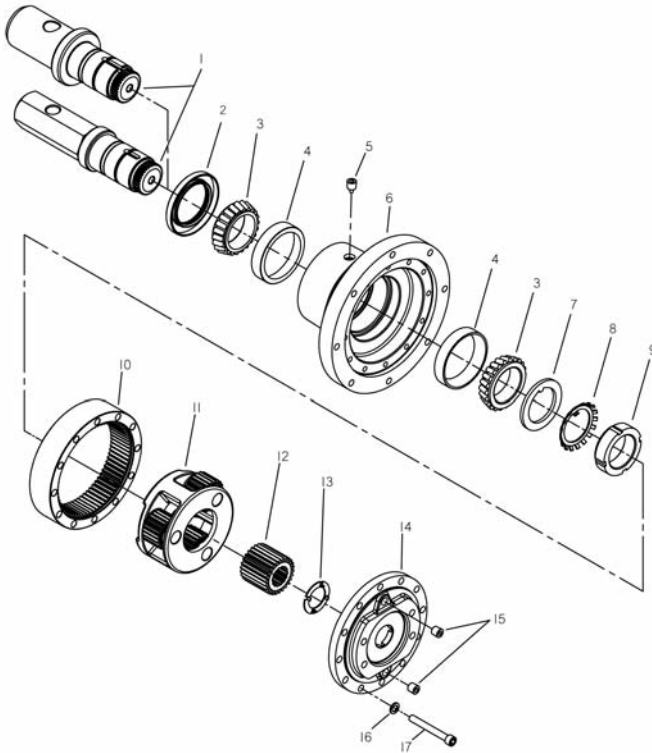

<u>Ref.#</u>	<u>Part #</u>	<u>Description</u>	<u>Qty</u>
1	69200	2" Hex Output Shaft.....	1
1	69201	2-9/16 Rnd. Output Shaft .....	1
2	69202	Oil Seal.....	1
3	69203	Bearing Cone .....	2
4	69204	Bearing Cup .....	2
5	69205	Magnetic Plug.....	1
6	69206	Hub .....	1
7	69207	Thrust Washer .....	1
8	69208	Lock Washer.....	1
9	69209	Lock Nut .....	1
10	69210	Ring Gear .....	1
11	69211	Secondary Carrier Assembly.....	1
12	69212	Sun Gear .....	1
13	69213	Thrust Washer .....	1
14	69214	Cover .....	1
15	69215	Pipe Plug .....	2
16	69216	Washer .....	12
17	69217	Screw, Socket Head Cap .....	12

**\* NOTE:** 1.5 Pints of Oil Required

*Output speed and torque specifications are based on theoretical values and are provided for comparative purposes only. Premier Auger is continually striving to improve its products. Therefore, we reserve the right to make changes to our products or specifications at any time without notice or obligation.*

## IDENTIFICATION

**IMPORTANT:** All Power Wheel units and kits are shipped with a label that includes the Auburn Gear part number and order code.

Example:



In addition to the label, Power Wheel drives are stamped with the last four digits of the part number and the date code, which appears on the cover or hub flange as shown.

Example: 3136 11240

When ordering parts, the information included on the label or the stamped identification number is necessary to accurately identify the drive and obtain the correct replacement parts.

## DISASSEMBLY OF POWER WHEEL

### STEP 1

Remove twelve socket head cap screws (17) and washers (16) from cover (14). Lift cover (14) from assembly. Thrust washer (13) usually remains with cover (14).

### STEP 2

Lift sun gear (12) from secondary carrier assembly (11).

### STEP 3

Remove secondary carrier assembly (11) from ring gear (10).

### STEP 4

Remove ring gear (10) from hub (6).

### STEP 5

One tab of lock washer (8) will be engaged in slot of bearing nut (9); bend back to release. Remove the bearing nut (9), lock washer (8) and thrust washer (7). **Note:** A special locknut wrench (P/N: 613A) is required for the removal of the bearing locknut. Contact Auburn Gear for procurement of wrench and other service tools.

### STEP 6

Care should be taken to avoid damaging splines and threads on shaft. Note: Bearing cone (3) has been designed with a slip fit with respect to shaft (1).

### STEP 7

Remove seal (2) and bearing cones (3) from hub (6). Inspect bearing cups (4) in hub (6) and remove only if replacement is required.

## ASSEMBLY OF POWER WHEEL

### STEP 1

Press new bearing cups (4) in each side of the hub (6). It is recommended that bearing cups (4) and cones (3) be replaced in sets.

### STEP 2

Assemble outer bearing cone (3) into cup (4) at seal end of hub (6) and press a new seal (2) into hub (6).

### STEP 3

Lubricate shaft oil seal (2) and lower hub (6) onto output shaft (1). Keep hub (6) centered to prevent damage to oil seal. **NOTE:** [On heavy duty seals there is to be no lubricant on seal (2), output shaft (1), or hub (6)].

### STEP 4

Assemble inner bearing cone (3) over output shaft (1). Place bearing cone (3) over output shaft bearing journal. Press bearing cone (3) down until rollers just touch cup (4). Take care to avoid pressing cone (3) too far.

### STEP 5

Install thrust washer (7) with tab in keyway of output shaft and lock washer (8). Install lock nut (9) and tighten to 30 ft-lbs (41 Nm). Rotate hub clockwise twenty turns then counter-clockwise twenty turns. Tighten lock nut (9) to 50 ft-lbs (68 Nm). Repeat rotation process and tighten to 70 ft-lbs (95 Nm).

### STEP 6

Secure lock nut (9) by bending lock washer tab (8) into one of the 4 slots of lock nut (9). If no tab from lock washer (8) aligns with slot of lock nut (9), lock nut (9) may be tightened until one of the slots aligns with lock washer tab (8).

### STEP 7

Clean mating surface and apply a bead of silicone sealant to face of hub (6) that mates with ring gear (10). See instructions on sealant package. Assemble ring gear (10) to hub (6), being careful to align bolt holes.

**STEP 8**

Assemble the secondary carrier assembly (11) into ring gear (10) aligning the gear teeth. Carrier splines mesh with splines on output shaft (1).

**STEP 9**

Install sun gear (12) into secondary carrier assembly (11). Sun gear (12) should turn freely by hand when assembled.

**STEP 10**

Apply a bead of silicone sealant to cover face of ring gear (10). Secure thrust washer (13) with tangs engaged in cover (14). **Note:** Washer (13) can be secured to cover (14) with a small amount of grease or silicone sealant. Assemble cover (14) to ring gear (10).

**STEP 11**

Install twelve socket head cap screws (17) and washers (16), and torque to 45-50 ft-lb (60-68 Nm).

**STEP 12**

Position filler opening vertically and fill with lubricant to proper level.

**CARRIER ASSEMBLIES**

It is recommended that the secondary carrier assembly (11) be serviced in their entirety to protect the integrity of the Power Wheel drive.

**LUBRICATION RECOMMENDATIONS**

**IMPORTANT: POWER WHEEL PLANETARY DRIVES ARE SHIPPED WITHOUT LUBRICANT AND MUST BE FILLED TO THE PROPER LEVEL PRIOR TO START UP.**

Observe lubrication recommendations given by the original equipment manufacturer. When specific recommendations are not available, use mild extreme pressure lubricant API-GL-5, No. 80 or 90 when filling the Power Wheel under normal temperature ranges between 0 - 120°F (-18 to 49°C). See specifications below for oil fill requirements for various Power Wheel mounting orientations. Use drain and fill plugs located in hub and cover. Oil is to be changed after first 50 hours of operation with subsequent changes every 1000 hours or yearly, whichever comes first. If ambient conditions are outside the specified range or if the oil temperature exceeds 200°F (93°C), contact Auburn Gear for oil and level recommendations.

**STORAGE**

A protective film is applied to the Power Wheel at the factory to prevent rust during shipment. Additional protection may be required if the Power Wheel is to be stored for an extended period of time.

**SEALING COMPOUND**

Silastic RTV732 sealer and General Electric Silimate RTV No. 1473 or RTV No. 1503 are currently recommended for sealing gasket surfaces. Sealant should be applied in a continuous bead, which should be centered on the surface to be sealed but should move to the inside of the hole at each bolthole location. For service requirements order Auburn Gear part number 604101.

**SPECIFICATIONS**

Maximum intermittent output torque .....	40,000 lb. in. (4,520 Nm)
Maximum input speed .....	3,500 RPM
Oil capacity (vertical, shaft down).....	1.5 pints (740 CC)

# DRIVE UNIT MOTOR EXPLODED VIEW MODELS MD06PD, MD09PD, MD12PD, MD14PD, MD18PD

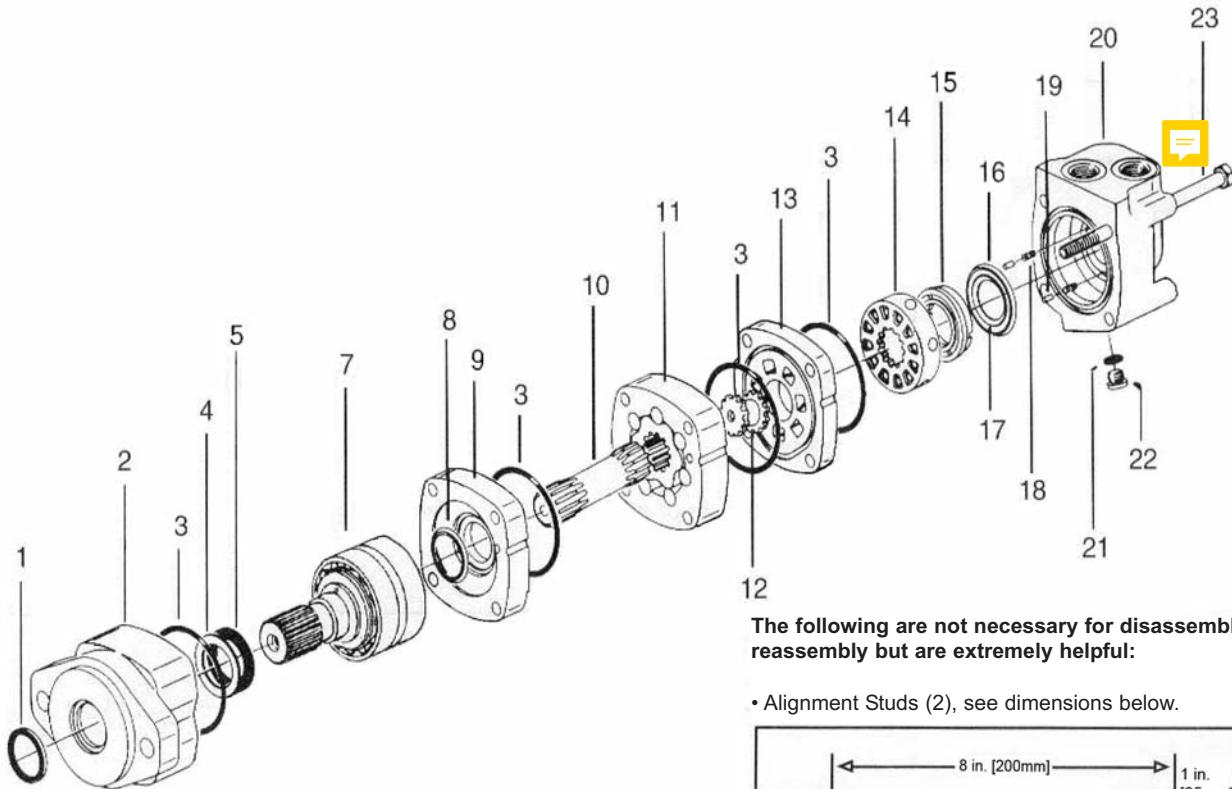

The following are not necessary for disassembly and reassembly but are extremely helpful:

- Alignment Studs (2), see dimensions below.

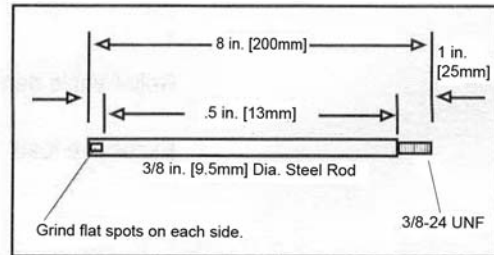

**NOTE:** Unless otherwise indicated, measurements are given in inches [mm] throughout the Hydraulic Motor Service Procedures.

**DRIVE UNIT MOTOR  
PARTS LIST  
MODELS MD06PD, MD09PD, MD12PD, MD14PD, MD18PD**

<u>Ref.#</u>	<u>Part #</u>	<u>Description</u>	<u>Qty</u>	<u>Models Used On</u>
1	62001	Dust Seal	1	All
2	62002	Bearing Housing	1	All
3	62003	Seal	4	All
4	62004	Back Up Washer	1	All
5	62005	Shaft Seal	1	All
7	62006	Bearing Shaft Assembly	1	All
8	62007	Shaft Face Seal	1	All
9	62008	Wear Plate	1	All
10	62051	Splined Drive	1	MD06
10	62052	Splined Drive	1	MD09
10	62053	Splined Drive	1	MD12
10	62010	Splined Drive	1	MD14
10	62011	Splined Drive	1	MD18
11	62054	Geroler	1	MD06
11	62055	Geroler	1	MD09
11	62056	Geroler	1	MD12
11	62014	Geroler	1	MD14
11	62015	Geroler	1	MD18
12	62017	Valve Drive	1	All
13	62018	Valve Plate	1	All
14	62019	Valve	1	All
15	62020	Balancing Ring	1	All
16	62021	Outer Face Seal	1	All
17	62022	Inner Face Seal	1	All
18	62021	Spring	2	All
19	62022	Pin	2	All
20	62023	Valve Housing	1	All
21	62024	Case Drain plug Seal	1	All
22	62025	Plug	1	All
23	62057	Tie Bolt	4	MD06
23	62058	Tie Bolt	4	MD09
23	62059	Tie Bolt	4	MD12
23	62027	Tie Bolt	4	MD14
23	62028	Tie Bolt	4	MD18
Not Shown	62060	Seal Kit	1	MD06, MD09, MD12
Not Shown	62030	Seal Kit	1	MD14, MD18

**Tools Required For Disassembly & Reassembly:**

- Torque Wrench 500 lb. in. Capacity
- 12-16 Breaker Bar
- 9/16" Socket
- Small Screwdriver 6-8 x 1/4" Blade
- 3/16" Allen Wrench
- Press
- Shaft Seal Installation Tool

# MOTOR SERVICE PROCEDURES

## DRIVE UNIT MODELS MD06PD, MD09PD, MD12PD, MD14PD, MD18PD

### DISASSEMBLY:

Cleanliness is extremely important when repairing a hydraulic motor. Work in a clean area. Before disconnecting the lines, clean the port area of the motor thoroughly. Use a wire brush to remove foreign material and debris from and around the exterior joints of the motor. Check the shaft and keyslot and remove all nicks, burrs or sharp edges that might damage the bearing housing seals when installing the shaft and the bearing assembly. Before starting the disassembly procedures, drain the oil from inside the motor.

1. Place the motor in a vise with the output shaft down (Fig.1). Clamp across the mounting flange of the motor, not the housing. Excessive clamping pressure will cause distortion. When clamping use some protective device on the vise, such as special soft jaws, pieces of hard rubber, or board.

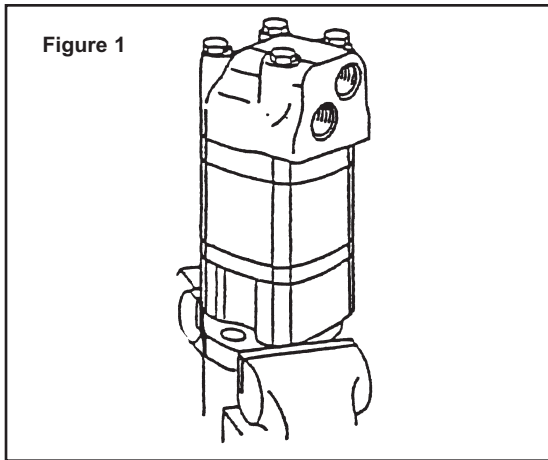

### NOTE

*Although not all drawings show the motor in a vise, we recommend that you keep the motor in the vise during disassembly and reassembly. Follow the clamping methods explained throughout the service procedures.*

2. Remove the 4 Tie Bolts from the motor (Fig.2).

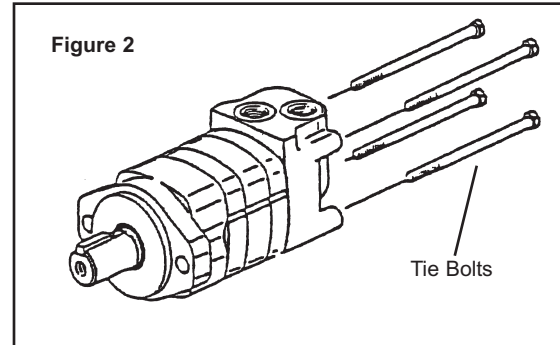

3. Lift Valve Housing straight up. If done carefully the Pins, Springs, Balance Ring Assembly, and Valve will remain on the Valve Plate (Fig. 3).

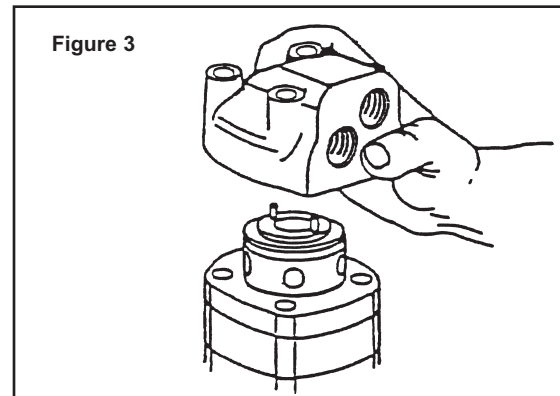

4. Carefully remove 3 [76] diameter seal from the Valve Housing (Fig. 4).
5. Remove case Drain Plug - with seal, from Valve Housing (Fig. 4).

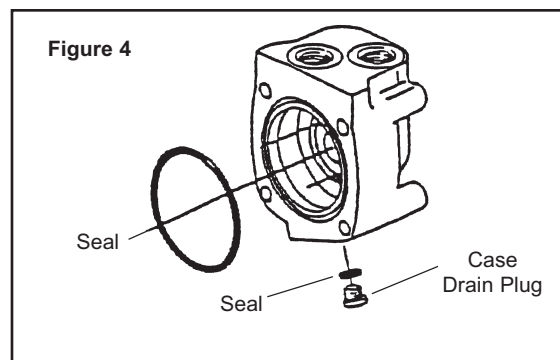



# MOTOR SERVICE PROCEDURES

## DRIVE UNIT MODELS MD06PD, MD09PD, MD12PD, MD14PD, MD18PD

6. Remove 2 pins and 2 springs from Balance Ring Assembly (Fig. 5).
7. Remove Balance Ring Assembly (Fig. 5).
8. Remove inner and outer face seals from Balance Ring (Fig. 5).
9. Remove the Valve (Fig. 5).

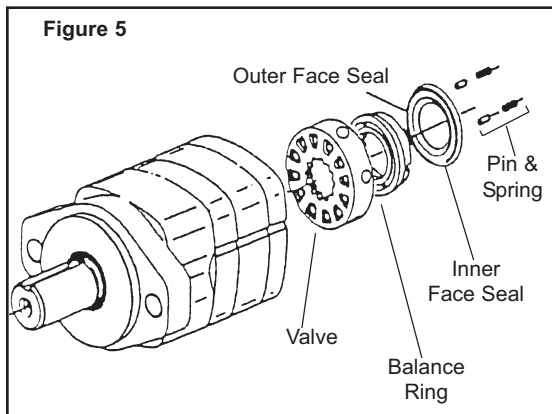

16. Remove the Shaft Face Seal from the Wear Plate.
14. Remove the 3 [76] dia. seal from Wear Plate (Fig. 8).
15. Remove the Wear Plate.
17. Remove the 3 [76] diameter seal from Bearing Housing (Fig. 8).

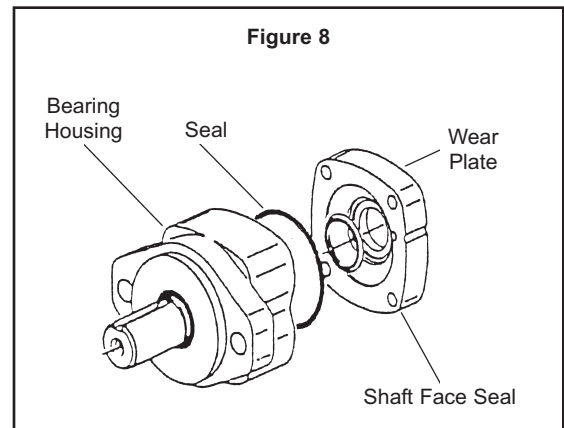

10. Remove the Valve Plate (Fig. 6).
11. Remove the 3 [76] dia. seal (Fig. 6).
12. Remove the Valve Drive.

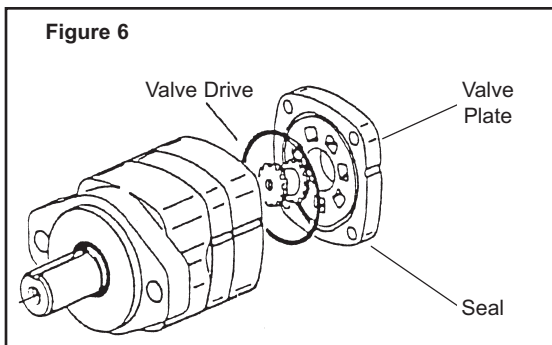

18. You may need a press to remove the Shaft and Bearing Assembly from the Bearing Housing (Fig. 9).

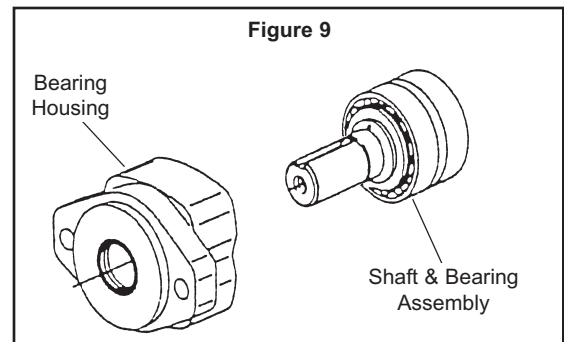

13. Remove the Geroler. Be sure to retain the rollers in the outer ring if they are loose. (Fig. 7).

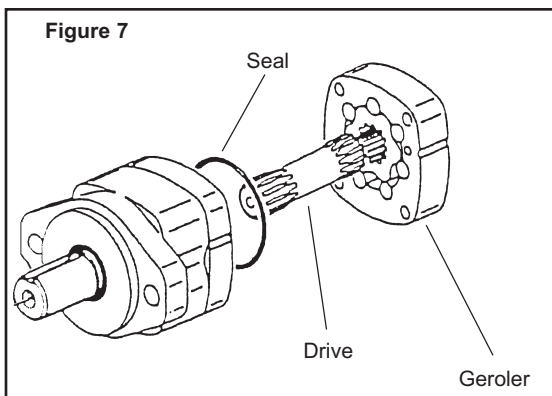

19. Use a small screwdriver to remove Shaft Seal, Back-up Washer and Dust Seal from Bearing Housing (Figure 10). **Do not damage bore of housing.**

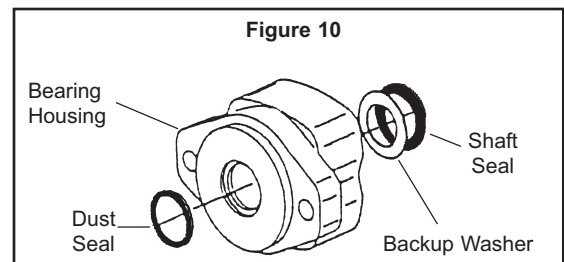

**NOTE:** Individual parts of shaft and bearing assembly are not sold separately. Replace as a unit.

# MOTOR SERVICE PROCEDURES

## DRIVE UNIT MODELS MD06PD, MD09PD, MD12PD, MD14PD, MD18PD

### REASSEMBLY:

Check all mating surfaces. Replace any parts that have scratches or burrs that could cause leakage. Clean all metal parts in cleaning solvent. Blow dry with air. Do not wipe dry with cloth or paper towel because lint or other matter can get into the hydraulic system and cause damage. Do not use a coarse grit or try to file or grind these parts. Check around the keyway and chamfered area of the shaft for burrs, nicks or sharp edges that can damage the seals when reassembling the bearing housing.

**NOTE:** Lubricate all seals (prior to installation) with petroleum jelly such as Vaseline. Use new seals when reassembling this motor. Refer to parts list for proper seal kit number.

20. Use a press to install dust seal in outer bore of Bearing Housing. Lip of seal must face outward (Fig. 11). If a press is not available use a plastic or rubber hammer, being careful not to damage or cock seal in the bore.

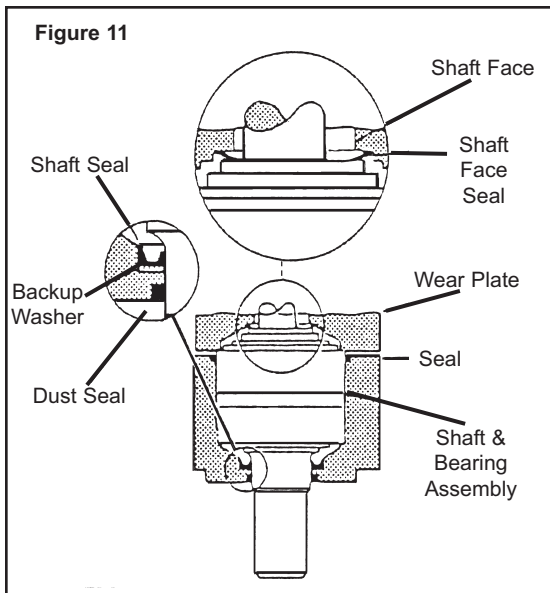

21. Place back-up washer into seal bore. Place shaft seal onto installation tool (#80-A3-300) and press seal onto seal bore of the housing.
22. Clamp housing on vise (see Fig. 1).
23. Place tape over shaft to prevent cutting the seals. Apply petroleum jelly to inside diameter of dust and shaft seal. You may need a press to install shaft and bearing assembly. Do not distort shaft seal. Damage to this seal will cause leakage.

24. Apply petroleum jelly to the 3 [76] diameter seal. Install seal into the bearing housing.
25. Alignment studs can be very helpful in reassembly of the motor (see special tools on page 22). If you use studs, install 2 studs diagonally opposed in the bearing housing.
26. Install the Shaft Face Seal in the Wear Plate as shown in Figure 11.
27. Install the Wear Plate (see Fig. 11).
28. Apply a light film of petroleum jelly to the 3 [76] diameter seal and install seal in the wear plate.
29. Install the drive in the bearing housing.
30. Align the notch on the outside of the Geroler with the notch on the wear plate. Install the Geroler against the wear plate. Be sure to retain the rollers in the outer ring if they are loose.

**NOTE:** Installation at this time involves 3 steps in the timing of the motor. Timing determines the direction of rotation of the output shaft. Timing parts include:

1. Geroler
2. Valve Drive
3. Valve Plate
4. Valve

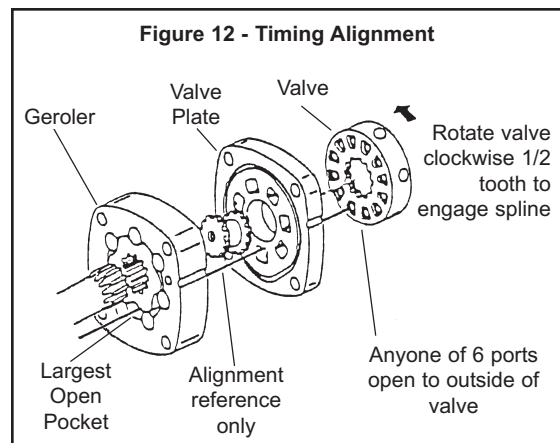

**Timing Step#1:** Locate the largest open pocket in the Geroler and mark it on the outside edge of the Geroler.

31. Install the valve drive in the Geroler.
32. Apply a light film of petroleum jelly to the 3 [76] diameter seal. Install seal in the groove of valve plate.
33. Align the notch on the outside of valve plate with the notch on the Geroler as shown in Figure 12.



# MOTOR SERVICE PROCEDURES

## DRIVE UNIT MODELS MD06PD, MD09PD, MD12PD, MD14PD, MD18PD

**Timing Step#2:** Locate the slot opening in the valve plate which is in line with the largest open pocket of the Geroler.

**Timing Step#3:** Locate any one of the side openings of the valve and align this opening with the open slot of the valve plate that is in line with the largest open pocket of the Geroler. Install the valve by rotating it clockwise until the spline teeth engage (1/2 spline tooth). This will provide the proper rotation when pressurized as shown in Fig. 13.

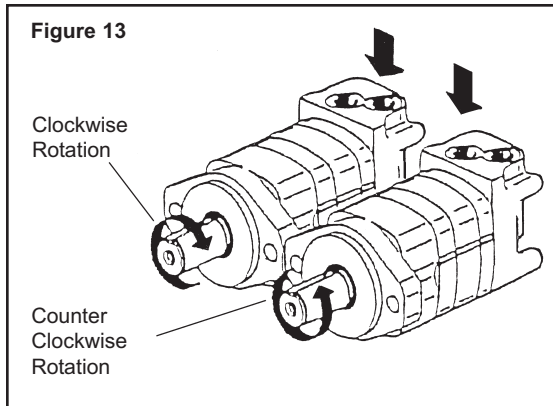

34. Install 2 springs and 2 pins in the holes located in the bore of the housing, as shown in Fig. 14.

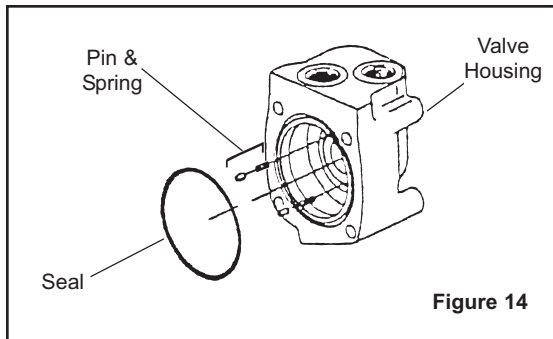

35. Apply a light film of petroleum jelly to the 3 [76] diameter seal. Install seal in the valve housing.

36. Apply petroleum jelly to inner and outer face seals. Install seals on balance ring as shown in Figure 15.

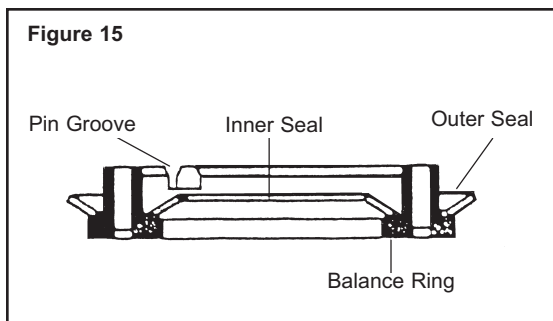

**IMPORTANT:** Install face seals in the positions shown in Figure 15 or the motor will not operate properly. Do not force or bend the face seals. Any damage to these seals will affect the operation of the motor.

37. Align pin grooves in balance ring with pins in bore of valve housing. Install balance ring assembly in valve housing.

38. Insert your finger through port of housing. Apply pressure to side of balance ring as shown in Fig. 16. Hold the ring in position until the valve housing is in place. Install valve against valve plate as shown in Figure 17.

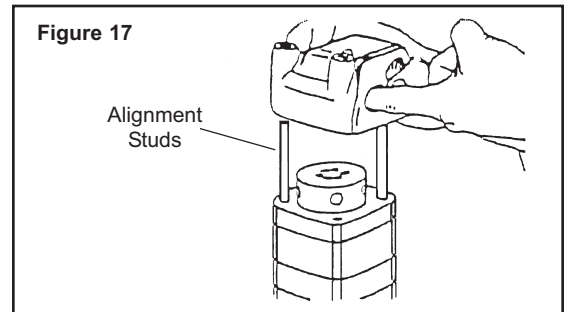
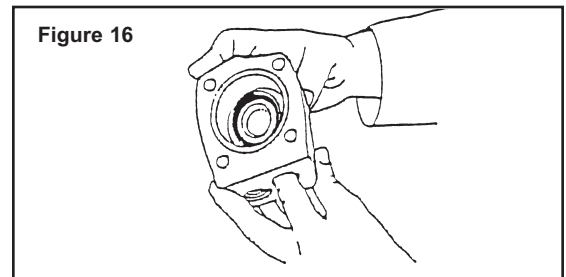

39. Install the tie bolts and finger tighten. Torque all four tie bolts alternately to 450 lb-in [50 nm].

40. Install seal on case drain plug then install in valve housing.

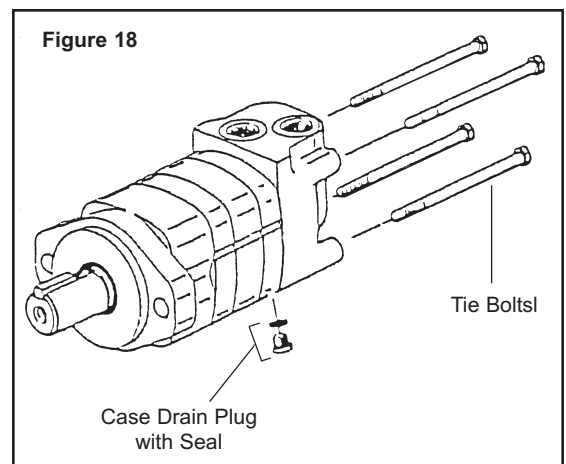

# ACCESSORIES & AUGER REPLACEMENT WEAR PARTS

## CONSTRUCTION AUGER TEETH

Wisdom Tooth .....	#00200
Chisel Tooth .....	#00201
Wisdom Gage Tooth.....	#00202
Hardfaced Wisdom Tooth.....	#00205
Hardfaced Chisel Tooth .....	#00206
Hardfaced Wisdom Gage Tooth.....	#00207
Carbide Wisdom Tooth.....	#00208
Carbide Chisel Tooth .....	#00209
RB Carbide Wisdom Tooth.....	#00237
Tooth Pocket for CDC Augers .....	#00225
Rock Auger Bullet Tooth.....	#00221
Bullet Tooth Holder.....	#00223
5/8"-11 Carriage Bolt 1-1/2" Long .....	#40000
5/8"-11 Lock Nut.....	#40001



Gage Tooth



Wisdom Tooth



Chisel Tooth



Rock Auger  
Bullet Tooth

## CONSTRUCTION AUGER PILOT POINTS

Fishtail Point.....	#00203
Hardfaced Fishtail Point.....	#00210
Carbide Fishtail Point.....	#00211
4-1/2" Auger Fishtail Point .....	#00204
Square Drive Lug .....	#00105
4" Auger Drive Lug .....	#00106
CDR Rock Auger Pilot - - with 1-3/4" Square Shank .....	#00236
- with 2-3/8" API.....	#00222
CDR Rock Auger Bullet Tooth .....	#00221
CRB Rock Auger Fishtail Point .....	#00239



Fishtail Point



CRB Rock  
Auger Fishtail  
Point



CDR Rock  
Auger Pilot

## HOSES & FITTINGS

Hydraulic Hoses 68" Long .....	#61061
Hydraulic Hoses 108" Long .....	#61050
Hydraulic Hoses 120" Long .....	#61049
Female Flat Faced Coupler .....	#61006
Male Flat Faced Coupler .....	#61007
Female Flat Faced Coupler .....	#61010
Male Flat Faced Coupler .....	#61011

## AUGER COLLARS

2" Hex Auger Collar .....	#00102
2-9/16" Round Auger Collar.....	#00101
2" Round Auger Collar .....	#00100
2-1/2" Hex Collar .....	#00103
2-5/8" Hex Collar .....	#00104

## MISCELLANEOUS WEAR PARTS

Knuckle Pin .....	#91001
Drive Unit Housing .....	#91000



